

80UZ41.5 -61
80UZ42.2 -61

Bend model:
BEND80-80 ANSI

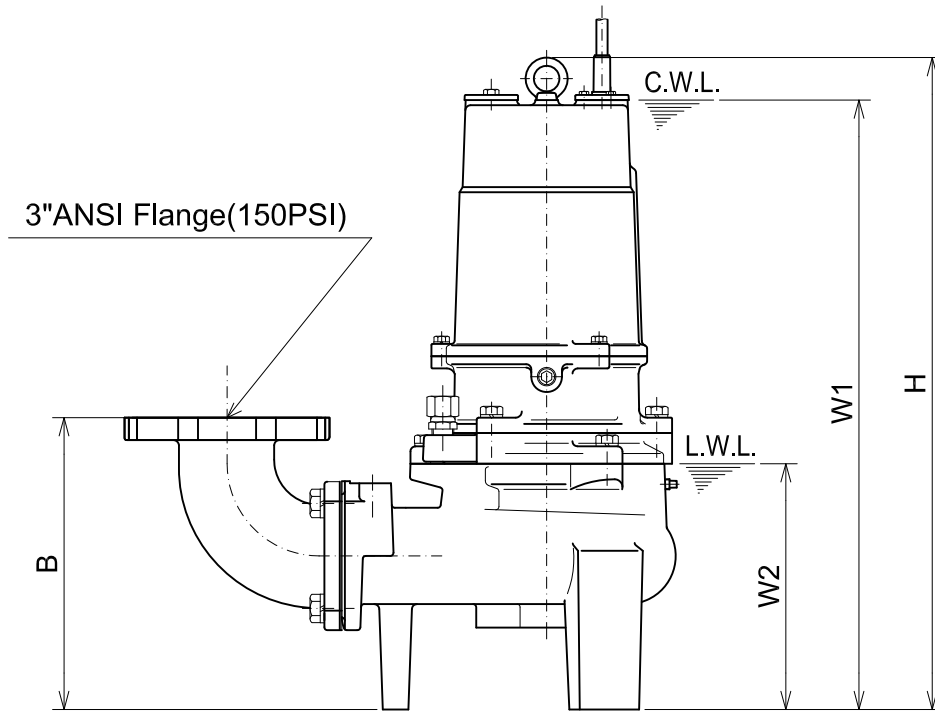
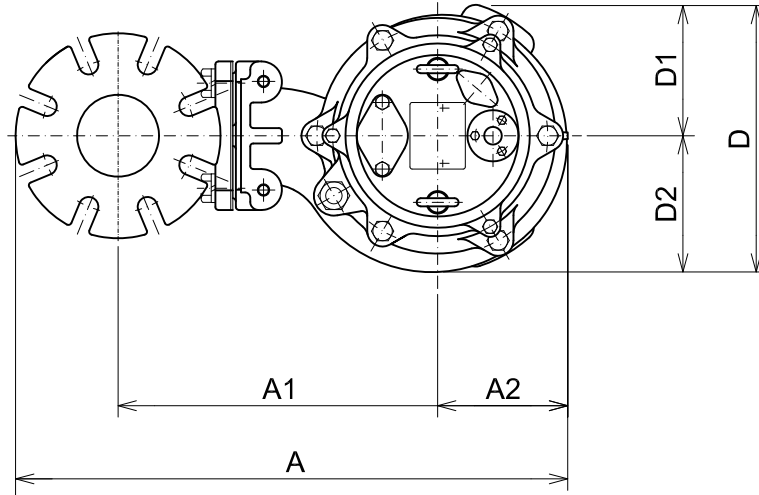

C.W.L. :Continuous running Water Level
L.W.L. :Lowest running Water Level

DIMENSIONS:USCS(Inch)

Model	HP	NOM. SIZE	Pump & Motor								C.W.L.	L.W.L.	*Wt. (lbs.)
			A	A1	A2	B	D	D1	D2	H			
80UZ41.5 -61	2	3"	21 5/8	12 11/16	5	11 1/4	10 1/4	5 1/16	5 1/4	25 1/16	23 3/8	9 1/2	141
80UZ42.2 -61	3	3"	21 5/8	12 11/16	5	11 1/4	10 1/4	5 1/16	5 1/4	25 1/16	23 3/8	9 1/2	141

DIMENSIONS:METRIC(mm)

Model	kW	NOM. SIZE	Pump & Motor								C.W.L.	L.W.L.	*Wt. (kg)
			A	A1	A2	B	D	D1	D2	H			
80UZ41.5 -61	1.5	80	549	322	127	285	261	128	133	637	595	240	64
80UZ42.2 -61	2.2	80	549	322	127	285	261	128	133	637	595	240	64

*Excluding Cable.



TSURUMI PUMP

UZ-SERIES
VORTEX - SEWAGE & WASTEWATER PUMPS

DIMENSIONS

TOS80UZ41.5 -61
TOS80UZ42.2 -61

Guide Rail System
Model : TOS3-80-80 ANSI
Wt. : 64lb. (29kg)

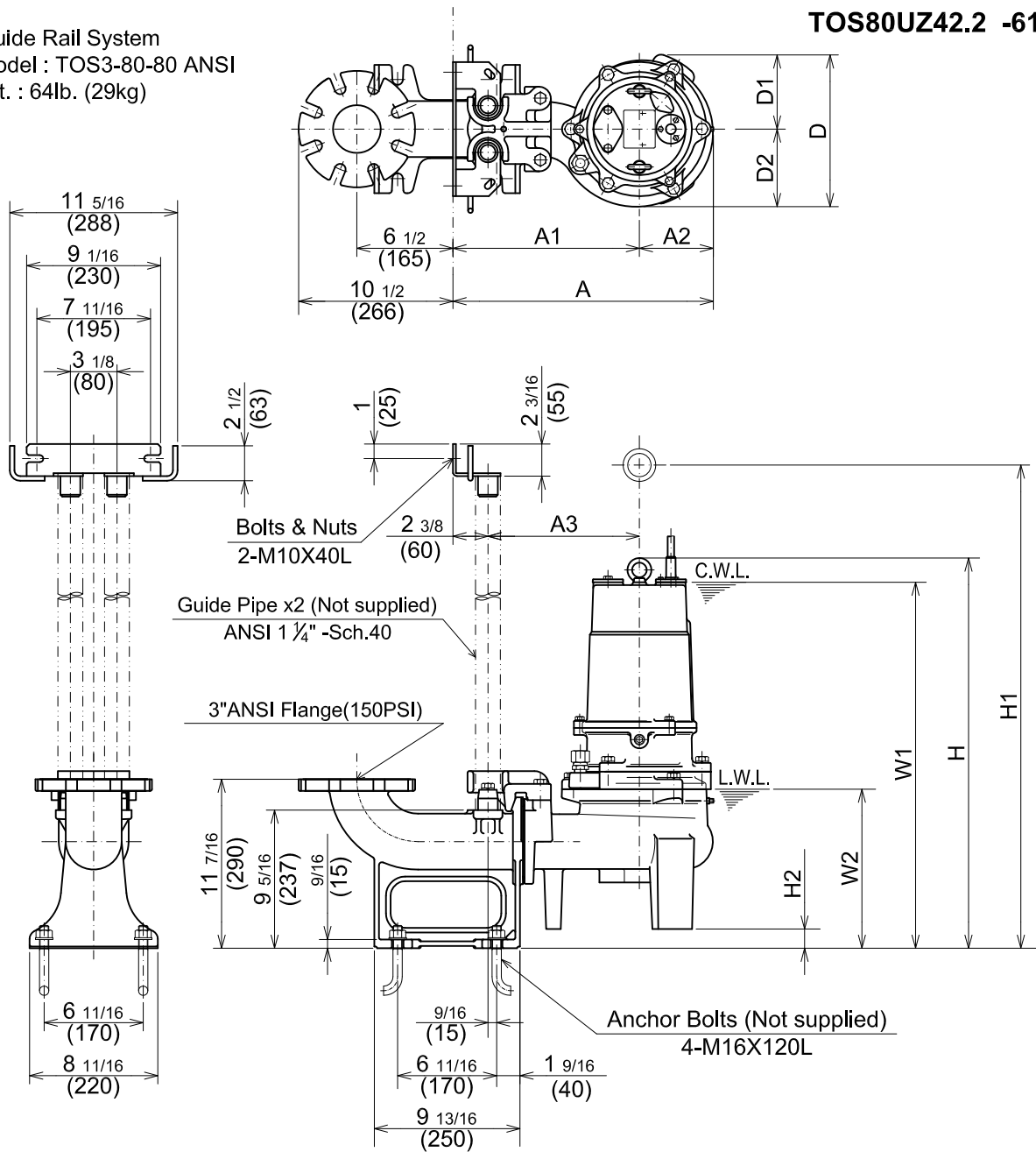

C.W.L. :Continuous running Water Level
L.W.L. :Lowest running Water Level

DIMENSIONS:USCS(Inch)

Model	HP	NOM. SIZE	Pump & Motor										C.W.L.	L.W.L.	*Wt. (lbs.)
			A	A1	A2	A3	D	D1	D2	H	H1	H2			
TOS80UZ41.5 -61	2	3"	17 5/8	12 5/8	5	10 1/4	10 1/4	5 1/16	5 1/4	26 3/8	31 1/8	1 5/16	24 3/4	10 7/8	123
TOS80UZ42.2 -61	3	3"	17 5/8	12 5/8	5	10 1/4	10 1/4	5 1/16	5 1/4	26 3/8	31 1/8	1 5/16	24 3/4	10 7/8	126

DIMENSIONS:METRIC(mm)

Model	kW	NOM. SIZE	Pump & Motor										C.W.L.	L.W.L.	*Wt. (kg)
			A	A1	A2	A3	D	D1	D2	H	H1	H2			
TOS80UZ41.5 -61	1.5	80	447	320	127	260	261	128	133	670	791	33	630	275	56
TOS80UZ42.2 -61	2.2	80	447	320	127	260	261	128	133	670	791	33	630	275	57

*Excluding TOS & Cable.



UZ-SERIES
VORTEX - SEWAGE & WASTEWATER PUMPS

PERFORMANCE
CURVE

MODEL	BORE	HP	KW	RPM	SOLIDS DIA.	LIQUID	SG.	VISCOSITY	TEMP.
(TOS)80UZ42.2 -61	3"/80mm	3	2.2	1700	3.15"/80mm	Water	1.0	1.123cSt.	60°F
PUMP TYPE	PHASE	VOLTAGE	AMPERAGE	HZ	STARTING METHOD	INS.CLASS			
Vortex-Sewage&Wastewater	3	208-230/460/575	9.2-8.6/4.3/3.5	60	Direct On Line	E			
CURVE No.	DATE	PHASE	VOLTAGE	AMPERAGE	HZ	STARTING METHOD	INS.CLASS		
-	-	-	-	-	-	-	-		

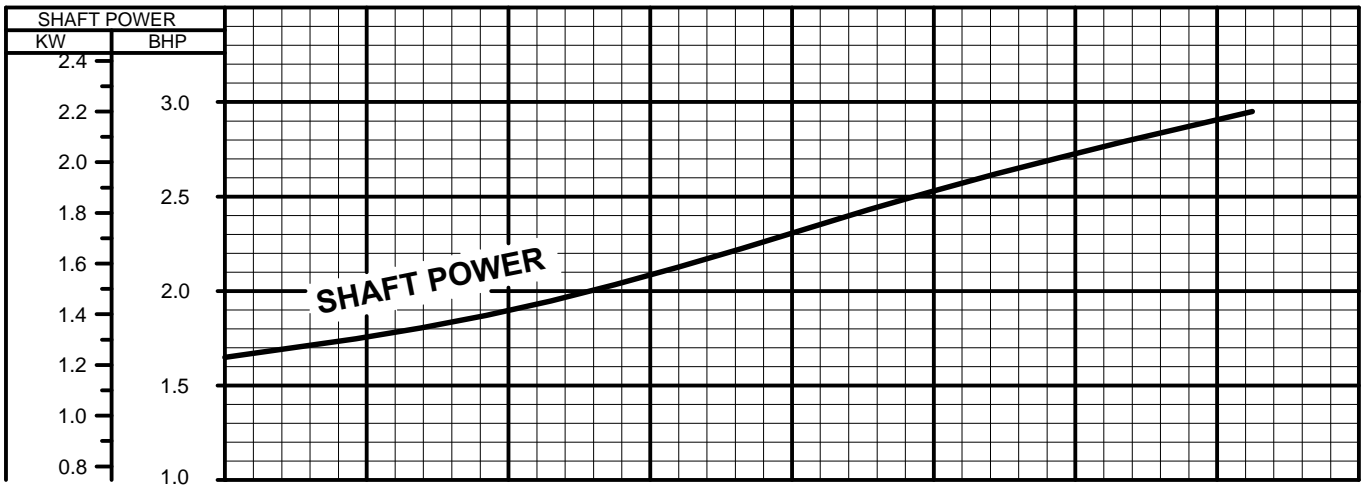
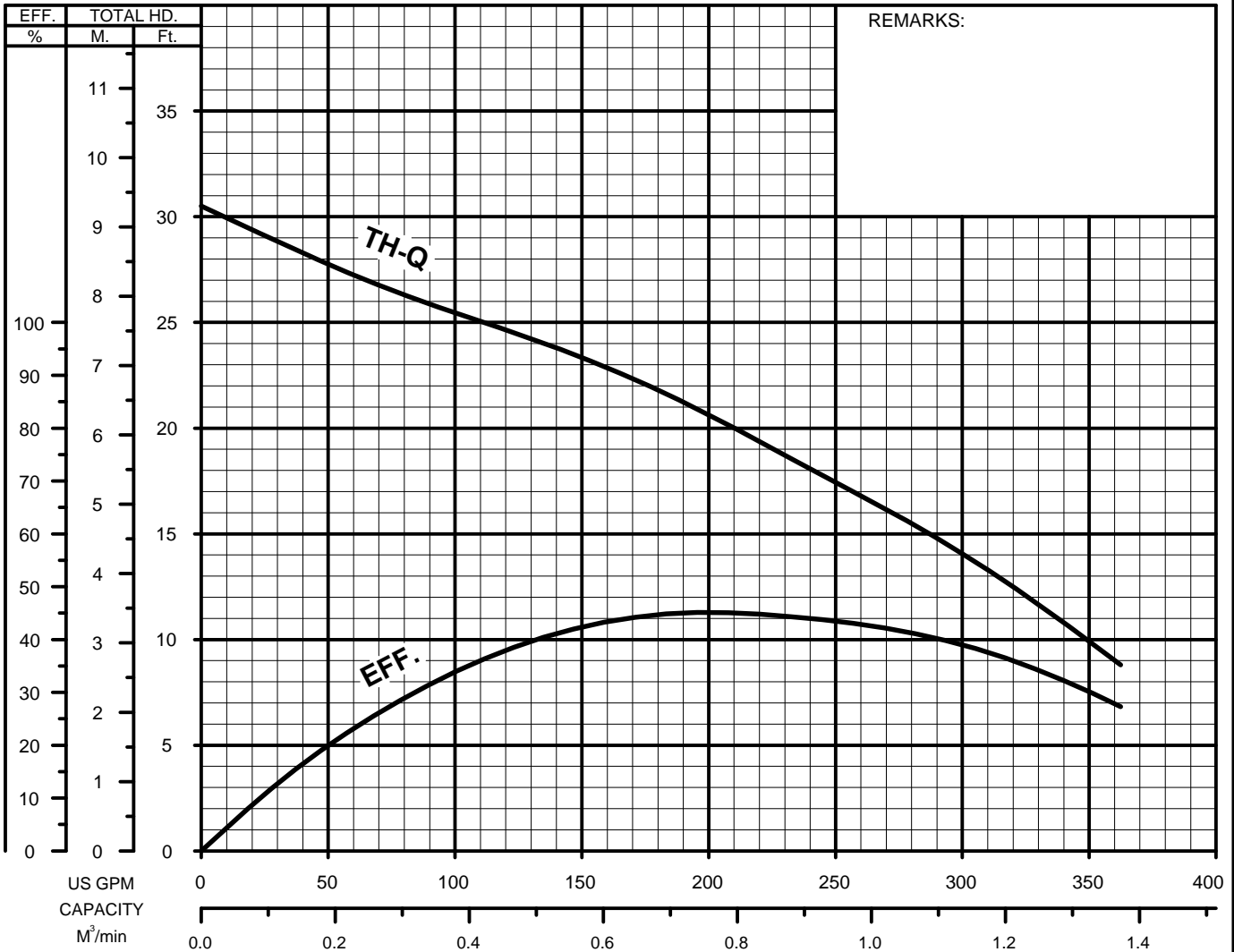



TSURUMI PUMP

**UZ-SERIES
VORTEX - SEWAGE & WASTEWATER PUMPS**

SECTIONAL VIEW

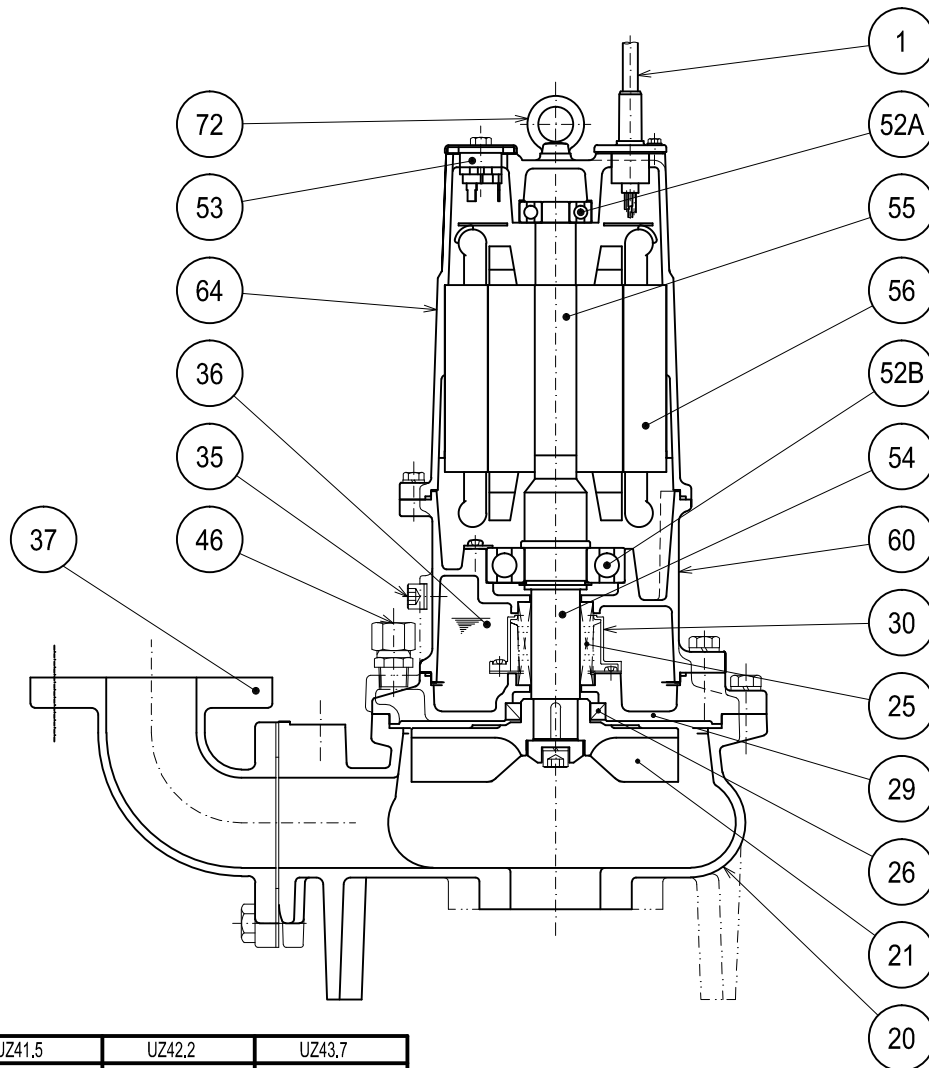

80UZ41.5 -61
80UZ42.2 -61
80UZ43.7 -61

	UZ41.5	UZ42.2	UZ43.7
* 1	AWG 16/4-32ft	AWG 14/4-32ft	AWG 12/4-32ft
* 2	H-30A	H-30A	H-35A
* 3	TC456812	TC456812	TC507212
* 4	#6307ZZC3	#6307ZZC3	#6309ZZC3

PART#	DESCRIPTION	MAIN MATERIAL / NOTE	RELATED ASTM,AISI CODE	RELATED EN CODE	QTY
1	Power Cable	PVC Sheath * 1			1
20	Pump Casing	Cast Iron	A48M Class30B	EN 1561 GJL-200	1
21	Impeller	Cast Iron	A48M Class30B	EN 1561 GJL-200	1
25	Mechanical Seal	Silicon Carbide / * 2			1
26	Oil Seal	NBR / * 3			1
29	Oil Casing	Cast Iron	A48M Class30B	EN 1561 GJL-200	1
30	Oil Lifter	PBT Plastic w/(GF+MD)40			1
35	Oil Plug	Stainless Steel	S 30400	1.4301	1
36	Lubricant	Turbine Oil ISO VG32 or SAE 10W-20			
37	Discharge Bend	Cast Iron / 3"ANSI Flange(150PSI)	A48M Class30B	EN 1561 GJL-200	1
46	Air Release Valve	Stainless Steel	S 30400	1.4301	1
52A	Upper Bearing	AC-#6304ZZC3			1
52B	Lower Bearing	* 4			1
53	Motor Protector				1
54	Shaft	Stainless Steel	S 42000	1.4028	1
55	Rotor				1
56	Stator				1
60	Bearing Housing	Cast Iron	A48M Class25B	EN 1561 GJL-150	1
64	Motor Housing	Cast Iron	A48M Class25B	EN 1561 GJL-150	1
72	Lifting Lug Bolt	Stainless Steel	S 30400	1.4301	2

PARTS LIST		SEWAGE & WASTEWATER PUMP				4/9/2018
ITEM	PART No.	DESCRIPTION	QTY	SIZE	MATERIAL	NOTES
1	001-149-21	Cabtyre Cable Set (32') 60Hz (USA)	1	VCT4Cx2mm2	BE/CE	
2	140-021-17	Hex.Bolt	3	M5x20	SUS304	
3	142-422-18	Seal Washer	3	PM-5	SUS+NBR	
4	003-111-20	Gland	1		SUS304	
5	009-105-16	Solderless Terminal	4	2mm2	CU	
6	140-052-17	Hex.Bolt	2	M8x16	SUS304	
7	127-107-17	Protector Fixing Plate	1	22/37-BE2	SUS304	replaces OLD part# 127-195-12
8	121-446-13	Packing	1	22/37-BE2	NBR	*
9	053-240-11	Motor Protector 208/230V-60Hz(USA)	1	KA313-GGXL103	(T.C)	
	053-421-18	Motor Protector 460V-60Hz(USA)	1	KA313-GQXL102	(T.C)	
10	142-111-24	Plain Washer	2	M4(D=8)	SPC	
11	143-015-17	Pan Screw	2	M4x10	SWRM	
12	072-100-20	Eye Bolt	2	M10	SUS304	
13	140-055-10	Hex.Bolt	3	M8x25	SUS304	
14	142-163-18	Spring Washer	3	M8	SUS304	
15	064-509-15	Motor Frame	1		FC	
16	122-333-19	O-Ring	1	170xd3.1	NBR	*
17	142-196-10	Wave Washer	1	6205/6304	SK5	
18	052-188-17	Bearing (w/O-ring)	1	AC-6304ZZC3		
19	058-000-46	Lead Wire Protection Plate	1	d70xd140x1.6t	Bakelite	replaces OLD part# 058-117-13
20	141-004-59	Hex.Nut	1	M6	SWRM	
21	009-159-15	Terminal	1	R-2-6	CU	
22	129-004-19	Stopper	1	M6x160(20/66)	SS	
23		Stator	1Set			
24	055-790-17	Rotor	1Set			
25	147-081-16	Impeller Key	1	7x7x22l	SUS420	
26	143-042-13	Pan Screw	3	M6x10	SWRM	
27	062-196-19	Bearing Fixing Washer	3	d8xd20.5x2.3t	SS	
28	052-110-18	Bearing	1	6307ZZC3		
29	146-022-16	Retaining Ring	1	C35	SK5	
30	140-098-15	Hex.Bolt	3	M12x35	SUS304	
31	142-165-10	Spring Washer	3	M12	SUS304	
32	060-373-16	Bearing Housing	1		FC	
33	121-247-12	Packing	1	d12.3xd18x2t	PE	*
34	035-113-18	Oil Plug	1	M12x14	SUS304	
35	025-194-12	Mechanical Seal	1	H-30	SiC	can substitute 025-279-12 (H-30A)
36	143-070-23	Pan Screw	2	M5x6	SWRM	
37	030-142-11	Oil Lifter	1	H-30(A)(T)	Resin	

PARTS LIST		SEWAGE & WASTEWATER PUMP				4/9/2018
ITEM	PART No.	DESCRIPTION	QTY	SIZE	MATERIAL	NOTES
38	143-070-10	Pan Screw	3	M5x6	SWRM	
39	030-151-13	Seal Stopper	1	H-30(A)(T)	SPCC	
40	140-098-15	Hex.Bolt	3	M12x35	SUS304	
41	142-165-10	Spring Washer	3	M12	SUS304	
42	046-000-03	Air Release Valve	1	PT-1/2	SUS304	
43	122-246-14	O-Ring	1	180xd3.1	NBR	*
44	029-386-15	Oil Casing	1	US41.5/42.2	FC	
45	142-301-10	Impeller Washer	1	M10	SUS304	
46	026-111-18	Oil Seal	1	TC-456812	NBR	
47	021-P40-13	Impeller (60Hz)	1	80UZ42.2-61	FC	
48	142-301-10	Impeller Washer	1	M10	SUS304	
49	142-164-19	Spring Washer	1	M10	SUS304	
50	140-284-10	Hex.Socket Cap Bolt	1	M10x20	SUS304	
51	140-130-36	Hex.Bolt	8	M16x70	SWRM	included in BEND80x80 kit (specify ANSI or NPT)
52	048-000-54	Screw Flange	1	NPT-3	FC	included in BEND80x80 kit (specify ANSI or NPT)
53	121-105-33	Packing	1	JIS10Kx80mm	NR	included in BEND80x80 kit (specify ANSI or NPT)
54	037-169-15	Discharge Bend	1	80x80mm	FC	included in BEND80x80 kit (specify ANSI or NPT)
55	142-166-37	Spring Washer	8	M16	SWRH	included in BEND80x80 kit (specify ANSI or NPT)
56	141-008-11	Hex.Nut	8	M16	SUS304	included in BEND80x80 kit (specify ANSI or NPT)
57	140-124-11	Hex.Bolt	4	M16x40	SUS304	included in BEND80x80 kit (specify ANSI or NPT)
58	121-152-19	Packing	1	145mm2(P.C.145)	NBR	* included in BEND80x80 kit (specify ANSI or NPT)
59	204-045-18	Plug	1	PT-1/8	SUS304	
60	020-B12-24	Pump Casing	1	80US41.5/42.2	FC	
	173-444-12	Packing O-Ring Set	1Set	(Marked by *)		
8	121-446-13	Packing (Protector Fixing Plate)	1	22/37-BE2	NBR	*
16	122-333-19	O-Ring (M.Frame/Brg.Housing)	1	170xd3.1	NBR	*
33	121-247-12	Packing (Oil Plug)	1	d12.3xd18x2t	PE	*
43	122-246-14	O-Ring (Brg.Housing/O.Casing)	1	180xd3.1	NBR	*
53	121-152-19	Packing (Discharge Bend)	1	145mm2(P.C.145)	NBR	*
		Lubricant		Turbine Oil VG32 1,250ml		

PARTS LIST		SEWAGE & WASTEWATER PUMP			4/9/2018	
ITEM	PART No.	DESCRIPTION	QTY	SIZE	MATERIAL	NOTES

EXPLODED VIEW

80UZ41.5-51/61 (80US41.5-50/60)
80UZ42.2-51/61 (80US42.2-50/60)

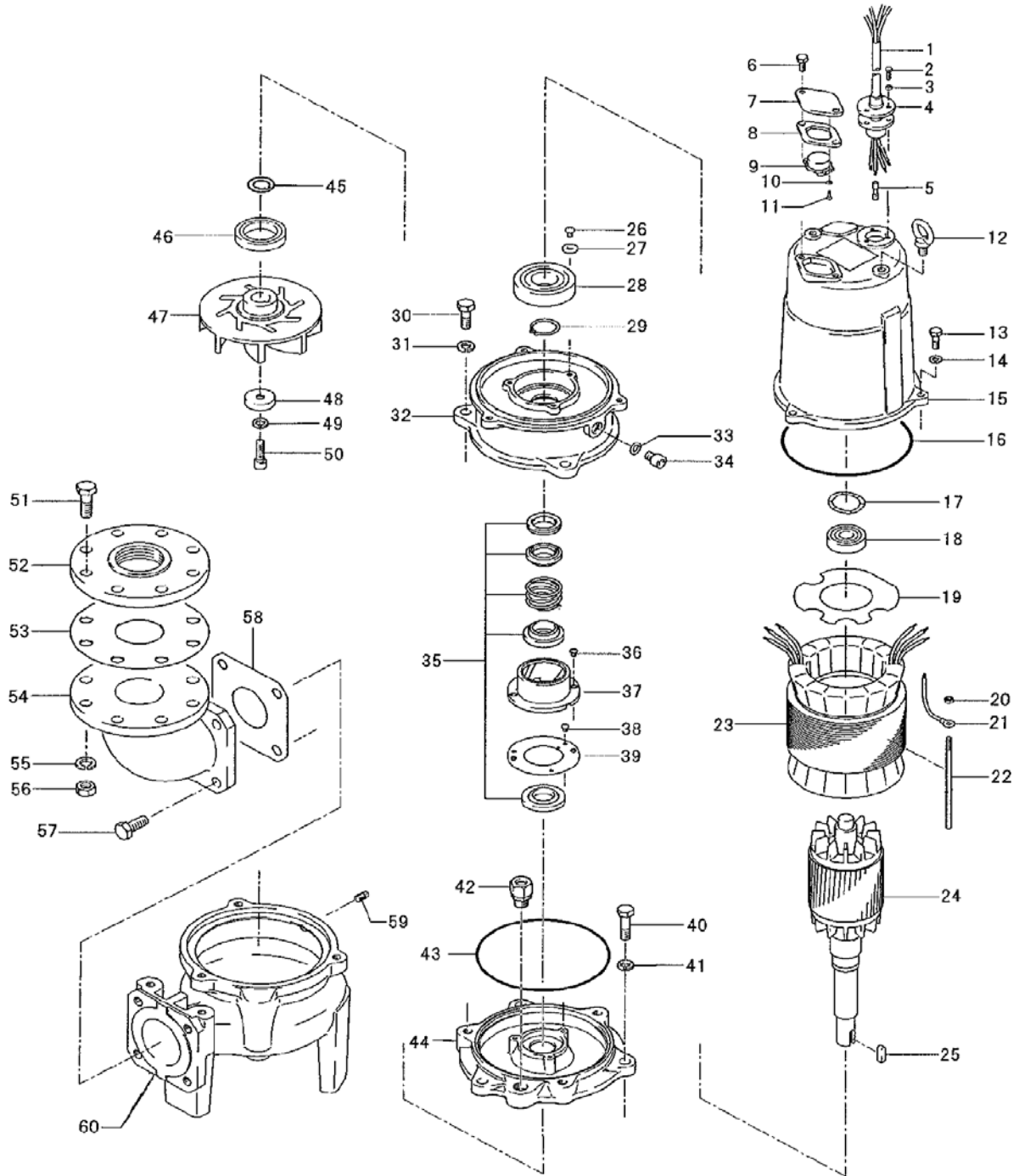

C-00317-1